

# B11 Control

The B11 Hand Control is designed to operate independently or as an integrated system connected to a Heavy Duty Accelerator Pedal, these hand controls are adaptable to a range of functions. Combined with our cable, they offer an extremely smooth system with excellent operator feedback.

## KEY FEATURES

- Rugged Construction – these hand controls are designed to perform smoothly under harsh environments typical to construction equipment and specialty vehicles.
- Adaptability – the B0011 can serve a wide range of purposes, including power take-off applications, throttle controls, mechanical shifting controls, or basic on-off functions.

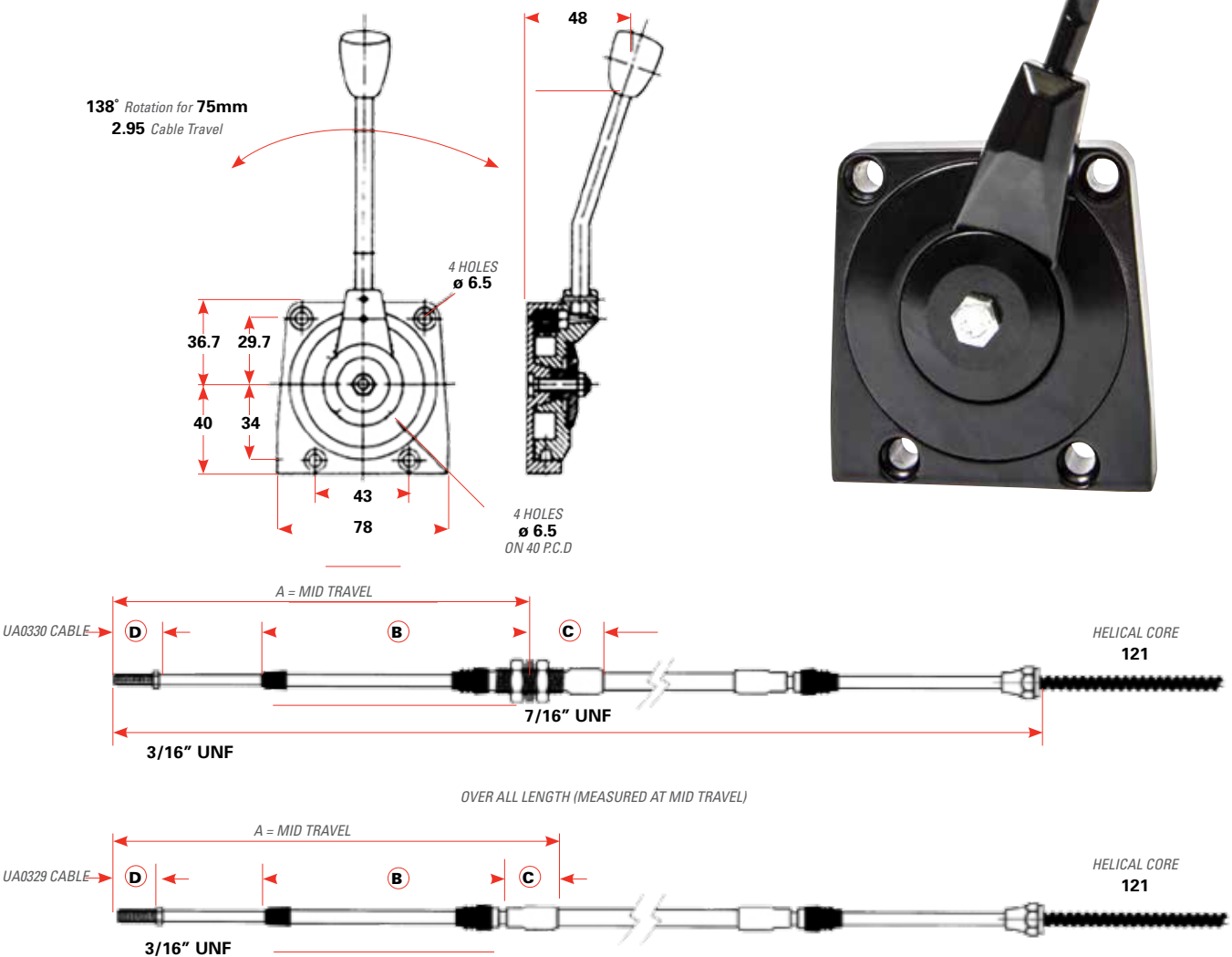

Code	Description
B0011	B11 Hand Control

Code	Description	Travel	"A" mm	"B" mm	"C" mm	"D" mm
UA0329	Clamp End Type UA0329	75	187.4	127	36.5	22
UA0330	Bulkhead End Type UA0330	75	169.9	109.4	33.3	22